

Process Equipment Efficiency Under Sea Motion

The external movement of process equipment from FPSO movement caused by sea motion can lead to internal liquid movement. In extreme cases, liquid movement can impede system operation and process efficiency. The internal liquid movement can have three scenarios:

1. change of liquid profile which leads to rise or fall of liquid levels at local areas
2. turbulence from the travelling fluid within the container
3. pressure exerted on to the containers by the liquid movement

ABSC has conducted a study to assess key equipment against predefined criteria making design or mitigation recommendations as appropriate. The study was based on spectral analysis, with implicit linear assumptions for the relationship from wave loading to FPSO response.

The sea state response of a ship is determined by given motion transfer functions, known as Response Amplitude Operators (RAO), for roll,

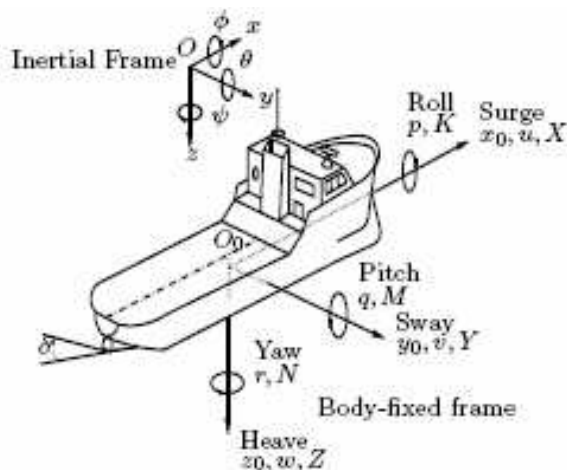

pitch, heave, sway and yaw. The methodology of analysis follows three analytical steps:

1. Identify equipment for motion analysis and establish design criteria
2. Determine characteristics of movement for the critical equipment

3. Liquid motion analysis, which is in two stages; calculation of the natural frequency of the liquid and detailed calculation of internal wave amplitude and internal wave forces.

In undertaking this work ABSC developed a proprietary package termed **UniMove**, with the following functionalities:

- **Equipment Response** - Determines the spectral characteristics of movement at any position on the FPSO for a given seastate and given RAO functions.
- Determines the spectral characteristics of liquid level changes and associated force on the container wall under external motion. Separate modules have been developed to consider:

Vertical Cylindrical Columns Horizontal Cylindrical Tanks Rectangular Tanks

The software can consider different seastates, wave directions, cargo loads and mitigation measures in the form of baffles.

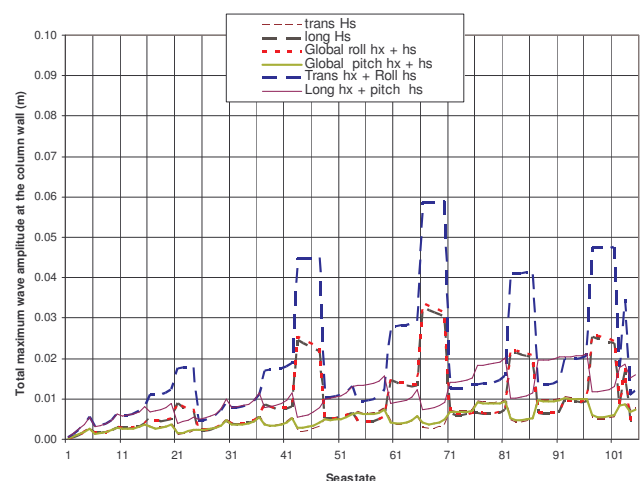

Example of output for a vertical cylindrical column showing maximum liquid rise against seastates